

# TS310 Datasheet

## TWO-STAGE PRESSURE REGULATOR



Gas  
  Liquid  
  Diaphragm  
  Piston  
  Self-Venting  
  Non-Venting  
 Max Inlet: 414 bar (6,000 psi)  
 Max Outlet: 25 bar (360 psi)  
 Cv 0.06



### INTRODUCING THE TS310...

The TS310 is a two-stage diaphragm-sensed pressure regulator, providing stable pressure control under decaying inlet conditions.

The first stage of the regulator is preset at the factory and locked to prevent alteration. The second stage of the regulator, with a PCTFE seat as standard, can be adjusted by the user between various outlet pressures within the range.

### SPECIFICATION

Max. Rated Inlet Pressure	414 bar (6,000 psi)
Outlet Ranges	Up to 25 bar (360 psi)
Design Proof Pressure	150% max. working pressure
Seat Leakage	In accordance with ANSI/FCI 70-3
Weight	1.5kg (3.3lbs)

### STANDARD MATERIALS OF CONSTRUCTION

PART	MATERIALS
Body and Bonnet	ASTM A479 316/316L Stainless Steel (UNS S31600/S31603)
Main Valve Pin	ASTM A479 316/316L Stainless Steel
Soft Seat	PEEK™ (450G) PCTFE (Kel-F)
Valve Spring	Inconel® X750 (UNS N07750)
Diaphragm	Inconel® X750
Handwheel	Nylon
O-Rings	FKM/FPM (Viton)
Loading Spring	ASTM A240 301 Stainless Steel (UNS S30100)

Note: Pressure regulator rating may be limited by connection type, Cv and/or seat material. Contact the office for specific pressure or temperature requirements.

### FEATURES AND BENEFITS

<p><b>1</b> METAL-TO-METAL SEATING DIAPHRAGM</p> <p>High working pressure, wide temperature range and good chemical compatibility.</p>	<p><b>2</b> 0.04% DECAYING PRESSURE EFFECT</p> <p>Stable outlet pressure under varying inlet conditions.</p>	<p><b>3</b> 'INTERSTAGE' RELIEF VALVE OPTION</p> <p>Ability to protect first stage from over pressurisation.</p>	<p><b>4</b> 40 MICRON INLET FILTER</p> <p>First stage soft seat protection from system contamination.</p>
--	--	--	---

Product availability and specifications contained herein are subject to change without notice. Consult local distributor or factory for potential revisions and/or service related issues. Pressure Tech Ltd support with product selection recommendations only - it is the users responsibility to ensure the product is suitable for their specific application requirements.



**PRESSURE TECH LTD**  
 Unit 24, Graphite Way, Hadfield, Glossop, Derbyshire, UK, SK13 1QH  
 +44 (0)1457 899 307 | [sales@pressure-tech.com](mailto:sales@pressure-tech.com) | [www.pressure-tech.com](http://www.pressure-tech.com)  
**DESIGNED, MANUFACTURED AND BUILT IN THE UK**  
 © 2024 Pressure Tech Ltd. All Rights Reserved.

# TS310 Datasheet

TWO-STAGE PRESSURE REGULATOR



Gas  
  Liquid  
  Diaphragm  
  Piston  
  Self-Venting  
  Non-Venting  
 Max Inlet: 414 bar (6,000 psi)  
 Max Outlet: 25 bar (360 psi)  
 Cv 0.06

## DRAWINGS AND INSTALLATION DIMENSIONS

Dimensions shown for 1/4" NPT option and standard configurations only - please contact the office for other options.

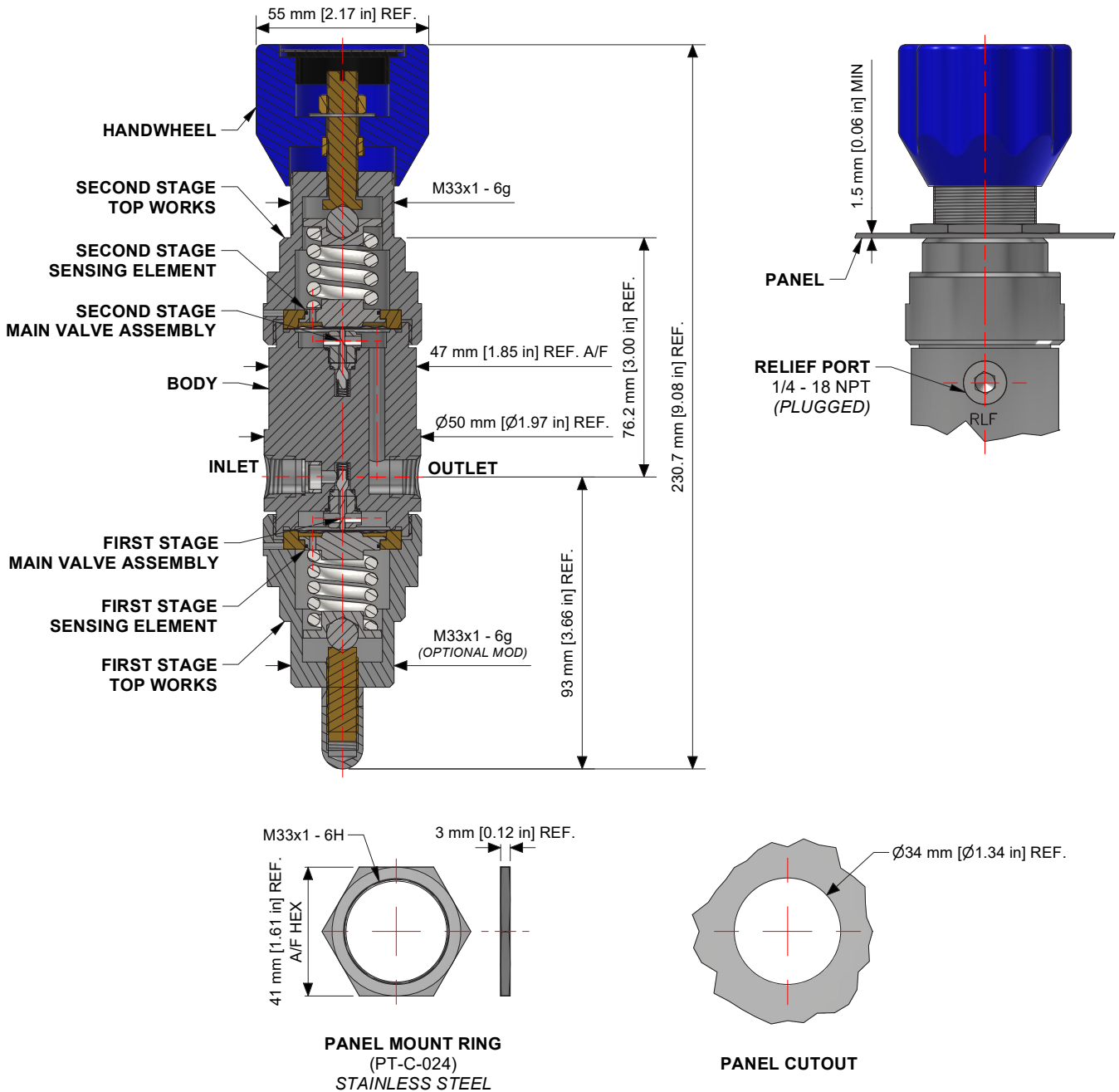

Note: All gauge ports are 1/4" NPT as standard.

Product availability and specifications contained herein are subject to change without notice. Consult local distributor or factory for potential revisions and/or service related issues. Pressure Tech Ltd support with product selection recommendations only - it is the users responsibility to ensure the product is suitable for their specific application requirements.



**PRESSURE TECH LTD**  
 Unit 24, Graphite Way, Hadfield, Glossop, Derbyshire, UK, SK13 1QH  
 +44 (0)1457 899 307 | [sales@pressure-tech.com](mailto:sales@pressure-tech.com) | [www.pressure-tech.com](http://www.pressure-tech.com)  
**DESIGNED, MANUFACTURED AND BUILT IN THE UK**  
 © 2024 Pressure Tech Ltd. All Rights Reserved.

# TS310 Datasheet

TWO-STAGE PRESSURE REGULATOR



Gas  
  Liquid  
  Diaphragm  
  Piston  
  Self-Venting  
  Non-Venting  
 Max Inlet: 414 bar (6,000 psi)  
 Max Outlet: 25 bar (360 psi)  
 Cv 0.06

## FLOW CURVE

Please contact the office for further information.

## PORTING CONFIGURATIONS

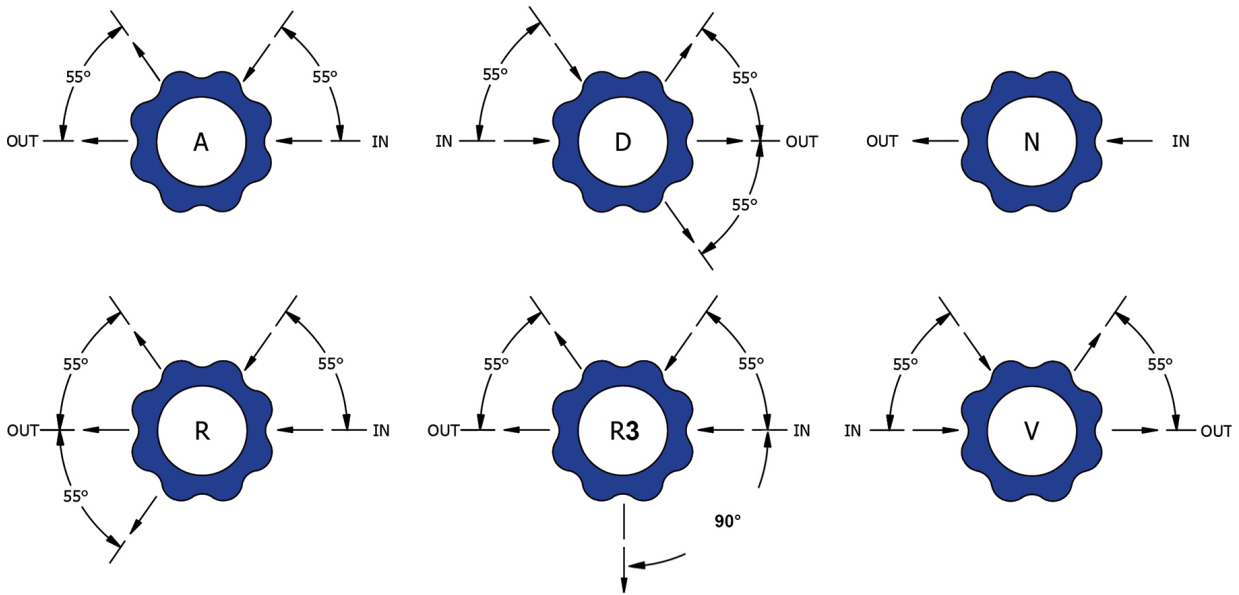

**Note:**

Additional porting configurations are available - please contact the office for further information.

Product availability and specifications contained herein are subject to change without notice. Consult local distributor or factory for potential revisions and/or service related issues. Pressure Tech Ltd support with product selection recommendations only - it is the users responsibility to ensure the product is suitable for their specific application requirements.



**PRESSURE TECH LTD**  
 Unit 24, Graphite Way, Hadfield, Glossop, Derbyshire, UK, SK13 1QH  
 +44 (0)1457 899 307 | [sales@pressure-tech.com](mailto:sales@pressure-tech.com) | [www.pressure-tech.com](http://www.pressure-tech.com)  
**DESIGNED, MANUFACTURED AND BUILT IN THE UK**  
 © 2024 Pressure Tech Ltd. All Rights Reserved.

# TS310 Datasheet

TWO-STAGE PRESSURE REGULATOR



Gas  
  Liquid  
  Diaphragm  
  Piston  
  Self-Venting  
  Non-Venting  
 Max Inlet: 414 bar (6,000 psi)  
 Max Outlet: 25 bar (360 psi)  
 Cv 0.06

## ORDERING INFORMATION

To build a Pressure Tech part number, simply combine the characters identified below in sequence:

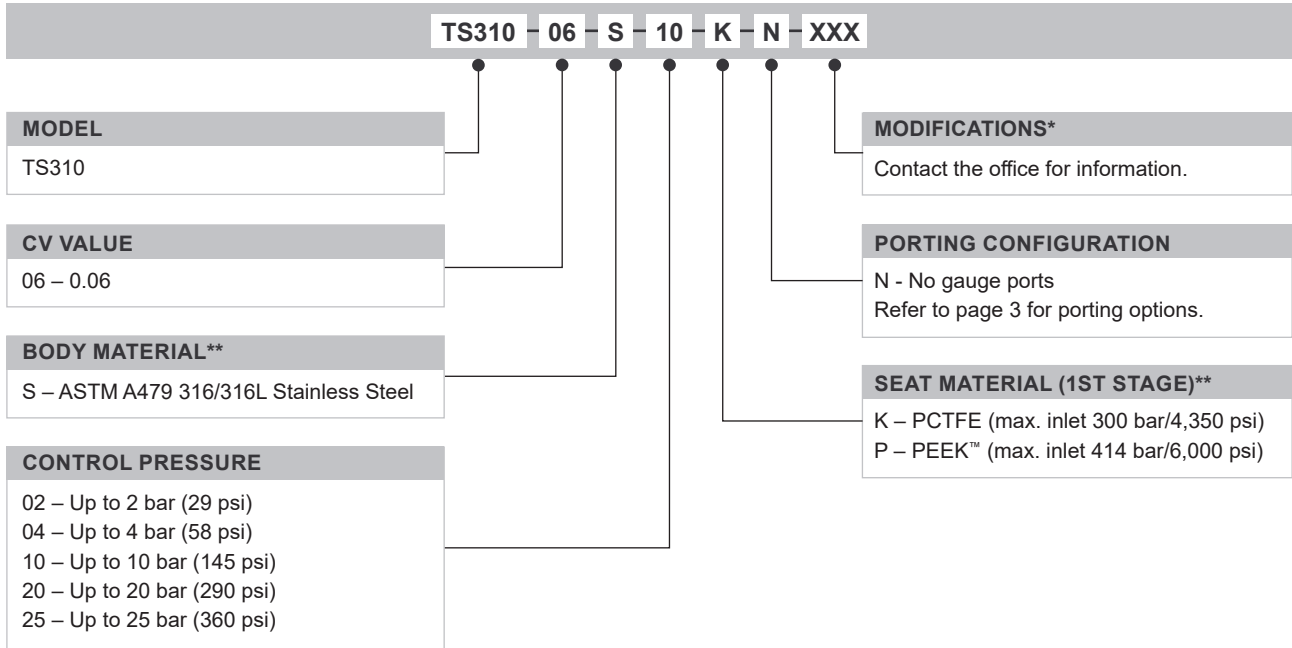

OPTIONAL EXTRAS		
	PART NUMBER	DESCRIPTION
Service Kit	SRK-TS310-06-U-K-M2-V	PCTFE SEAT and FKM/FPM seals
Service Kit	SRK-TS310-06-U-P-M2-V	PEEK™ SEAT and FKM/FPM seals
Panel Mounting Ring	PT-C-024	-

*Note:* Ancillary equipment also available

**TRADEMARKS:** PEEK™ is a trademark of Victrex PLC  
Inconel® is a registered trademark of Inco Alloys International

\* Where applicable  
\*\* Other materials may be available

Product availability and specifications contained herein are subject to change without notice. Consult local distributor or factory for potential revisions and/or service related issues.  
Pressure Tech Ltd support with product selection recommendations only - it is the users responsibility to ensure the product is suitable for their specific application requirements.



**PRESSURE TECH LTD**  
Unit 24, Graphite Way, Hadfield, Glossop, Derbyshire, UK, SK13 1QH  
+44 (0)1457 899 307 | [sales@pressure-tech.com](mailto:sales@pressure-tech.com) | [www.pressure-tech.com](http://www.pressure-tech.com)  
**DESIGNED, MANUFACTURED AND BUILT IN THE UK**  
© 2024 Pressure Tech Ltd. All Rights Reserved.